



Adaptor sleeves for MT with drawbar thread DIN 6364
 Douilles de réduction pour CM avec filetage DIN 6364

(DIN 69893-1 | HSK-A)



Verwendung:
 Zum Spannen von Werkzeugen mit Morsekegelschaft und Anzugsgewinde nach DIN 228-1 Form A.

Application:
 For clamping tools with Morse taper shank and thread according to DIN 228-1 form A.

Application:
 Pour le serrage d'outils avec queue cône Morse et filetage suivant DIN 228-1 forme A.

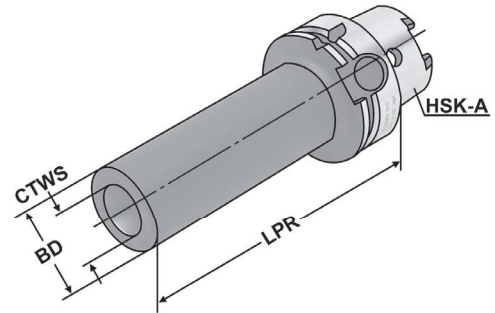

ISO 12164 Form A $\leq 5\mu\text{m}$ G6.3 15.000 min⁻¹ RFID Chip DIN 6364 AT5

Bestell-Nr. Order no. Référence	HSK	CTWS	THID	LPR	BD
A50.08.01	HSK-A 50	1	M6	100	25
A50.08.02	HSK-A 50	2	M10	120	32
A50.08.03	HSK-A 50	3	M12	140	40
A63.08.01	HSK-A 63	1	M6	100	25
A63.08.02	HSK-A 63	2	M10	120	32
A63.08.03	HSK-A 63	3	M12	140	40
A63.08.04	HSK-A 63	4	M16	160	48
A80.08.01	HSK-A 80	1	M6	110	25
A80.08.02	HSK-A 80	2	M10	120	32
A80.08.03	HSK-A 80	3	M12	150	40
A80.08.04	HSK-A 80	4	M16	170	48
A100.08.01	HSK-A 100	1	M6	110	25
A100.08.02	HSK-A 100	2	M10	120	32
A100.08.03	HSK-A 100	3	M12	150	40
A100.08.04	HSK-A 100	4	M16	170	48
A100.08.05	HSK-A 100	5	M20	200	63

5

Lieferumfang: Mit eingebauter Fräseranzugsschraube
Delivery: With built-in tightening bolt
Livraison: Avec vis de serrage montée

